



Contents	
5	PERIPHERALS
6	OPTIONAL ELEVATOR CONN

Revisions			
Rev	Description	Date	Approved
A	Initial prototype version	18-Dec-09	C. Jarvis
B	Production version	09-Feb-10	P. Lajsner
C	FIXED SCI LEVEL SH. BETWEEN QE AND JM MCU	15-Mar-10	P. Lajsner

		<b>Microcontroller Solutions Group</b>	
		6501 William Cannon Drive West Austin, TX 78758-8598	
This document contains information proprietary to Freescale Semiconductor and shall not be used for engineering design, procurement or manufacture in whole or in part without the express written permission of Freescale Semiconductor.			
Designer: Petr Gargulak		ICAP Classification: FOP: FLUQ: X PUBI:	
Drawing Title: Petr Gargulak		<b>TWR-SENSOR</b>	
Drawn by: Petr Gargulak		<b>TITLE PAGE</b>	
Approved: TBD	Size C	Document Number SCH-26439 PDF: SPF-26439	Rev C
Date: Monday, March 15, 2010		Sheet 1 of 6	



ICAP Classification: FCP: FIUC: X PUBI: _____		
Drawing Title: <b>TWR-SENSOR</b>		
Page Title: <b>NOTES</b>		
Size C	Document Number SCH-26439 PDF: SPF-26439	Rev C
Date: Monday, March 15, 2010	Sheet 2	of 6

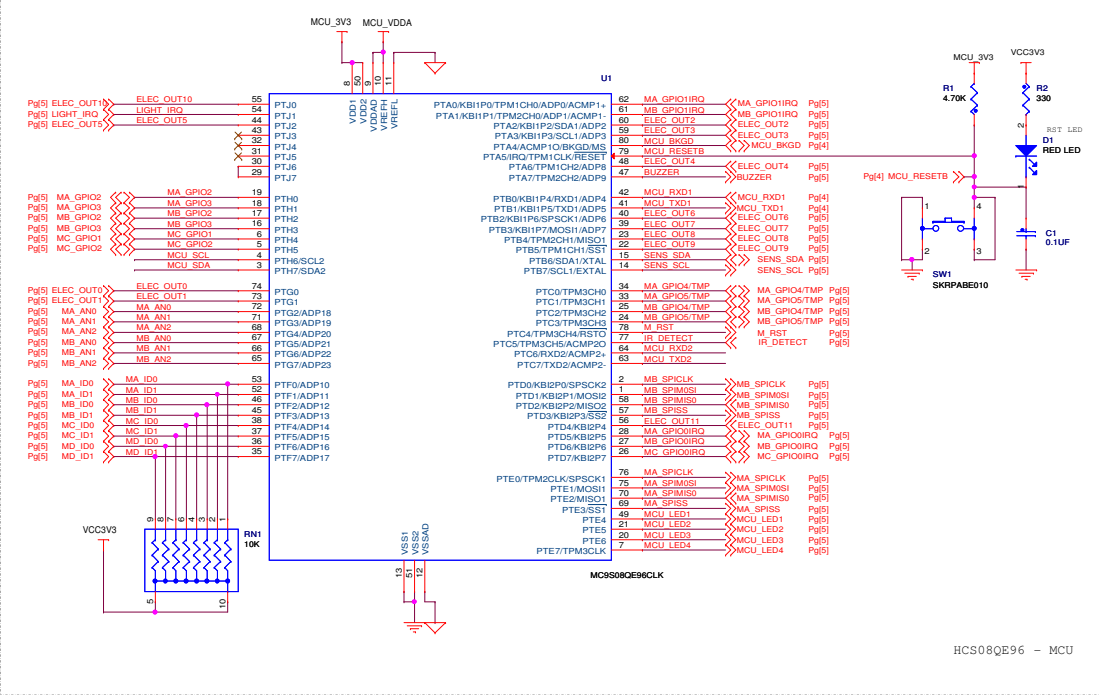

HCS08QE96 - MCU

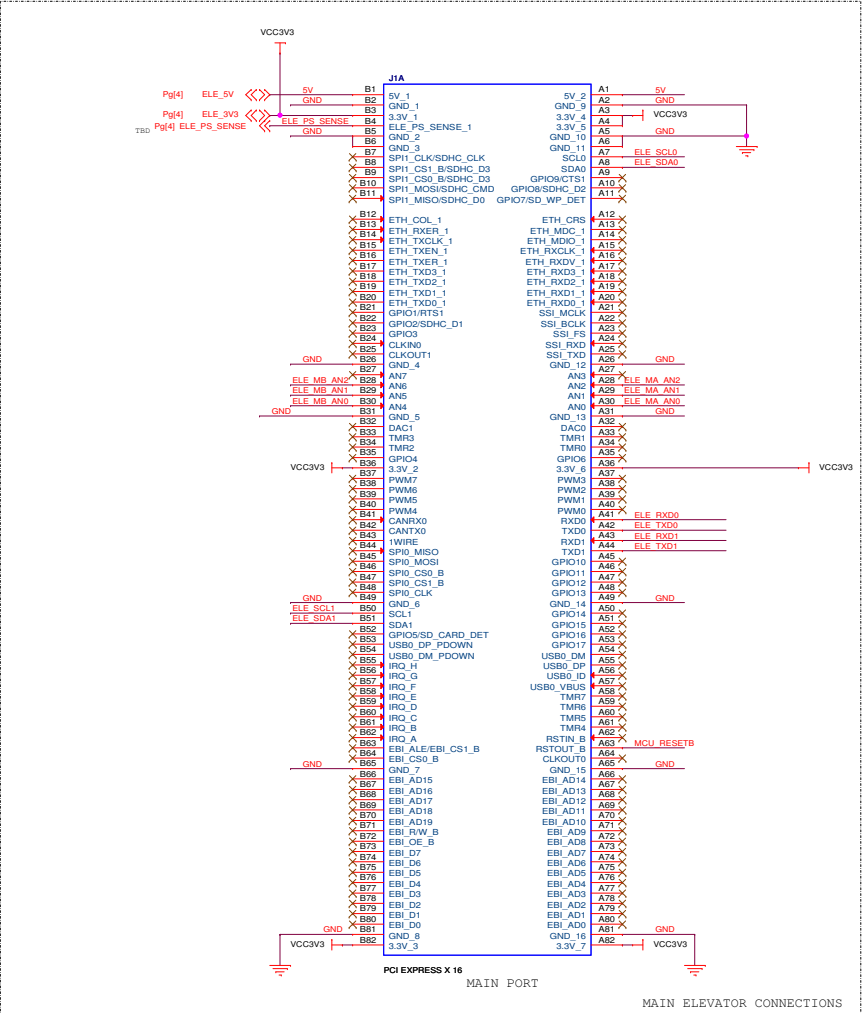

MAIN PORT MAIN ELEVATOR CONNECTIONS

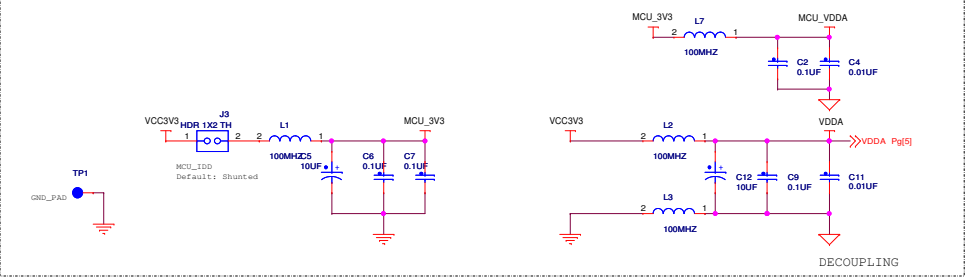

DECOUPLING

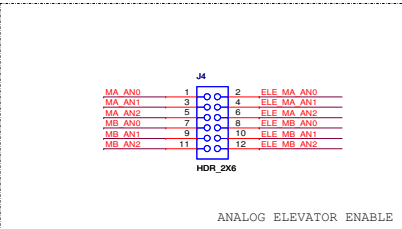

ANALOG ELEVATOR ENABLE

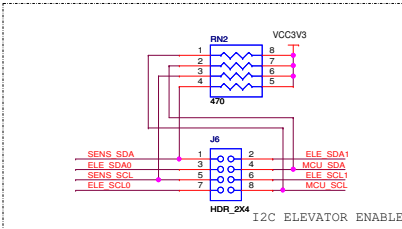

I2C ELEVATOR ENABLE

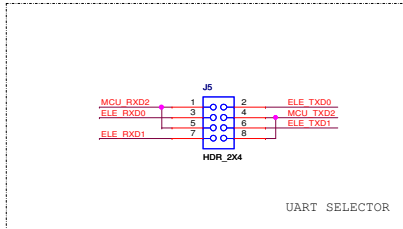

UART SELECTOR

FreeScale Semiconductor logo and product information:

ICAP Classification: FCP, FIUC: X, PUBI: ...

Drawing Title: **TWR-SENSOR**

Page Title: **HCS08QE96-MCU**

Size C, Document Number SCH-26439 PDF: SPF-26439, Rev C

Date: Thursday, April 08, 2010, Sheet 3 of 6

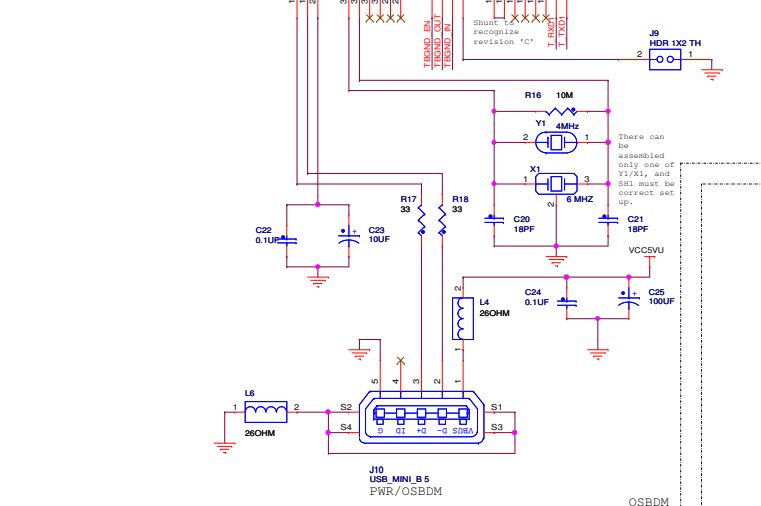
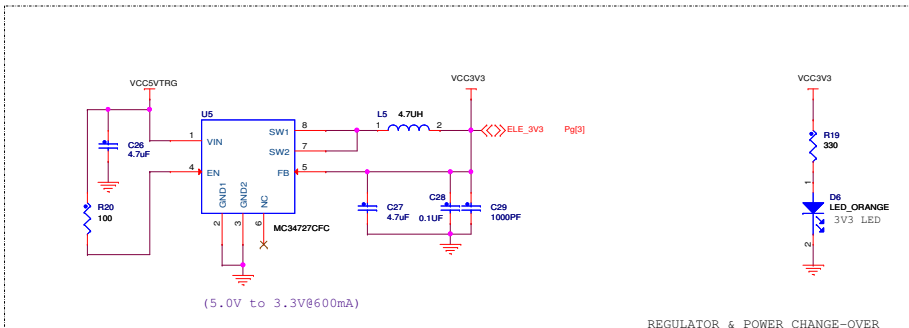
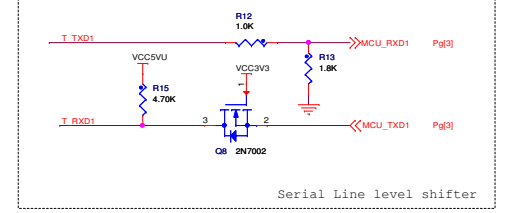
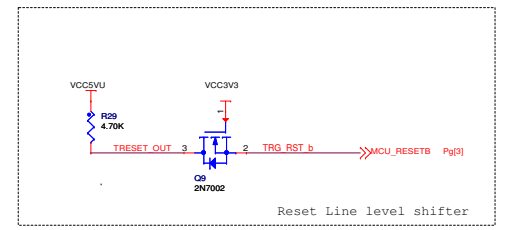
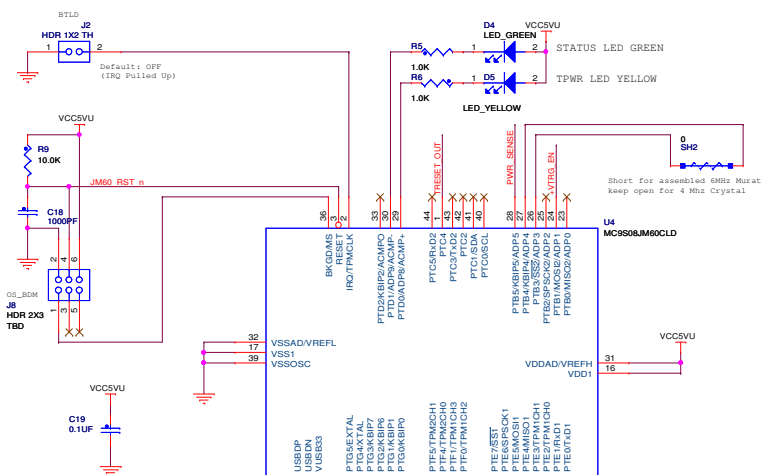
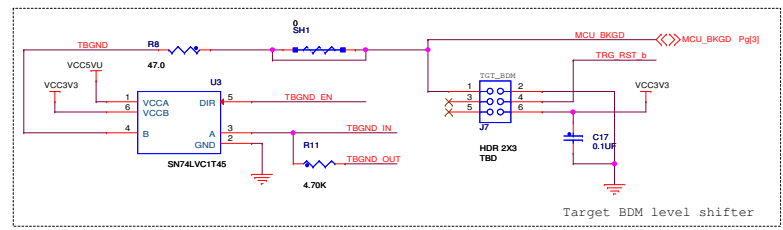
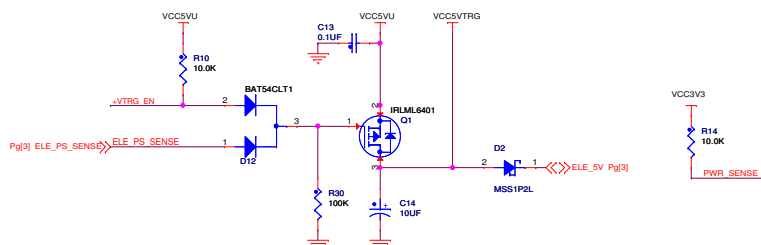

		ICAP Classification: FCP: FIUC: X PUBL:	
		Drawing Title: <b>TWR-SENSOR</b>	
Page Title: <b>OSBDM &amp; POWER CHANGEOVER</b>			
Size C	Document Number	Rev C	
SCH-26439 PDF: SPF-26439			
Date:	Thursday, April 15, 2010	Sheet	4 of 6



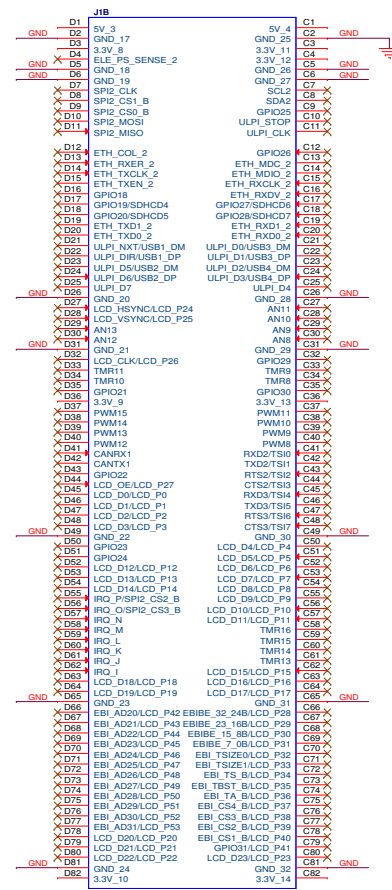

PCI EXPRESS X 16  
DUMMY PORT

**freescale**  
semiconductor

ICAP Classification: FCP: FUC: X PUB: \_\_\_\_\_  
Drawing Title: **TWR-SENSOR**

Page Title: **OPTIONAL ELEVATOR CONN**

Size C	Document Number SCH-26439 PDF: SPF-26439	Rev C
Date: Monday, March 15, 2010	Sheet 6 of 6	